

Card Trick

When printing the templates, ensure that paper size is set to A4, and scale to 100%

APRIL

This is a fairly new block as it first appeared in Beth Gutcheon's *The Perfect Patchwork Primer* in 1976.

It has become a favourite and often appears in sampler quilts. It's easy to piece but care needs to be taken in the placement of the colours to achieve the right effect.

The block is planned for 3 fabrics but you can vary this.

Fabric 1 - Dark Green

Fabric 2 - Light Green

Fabric 3 - Red

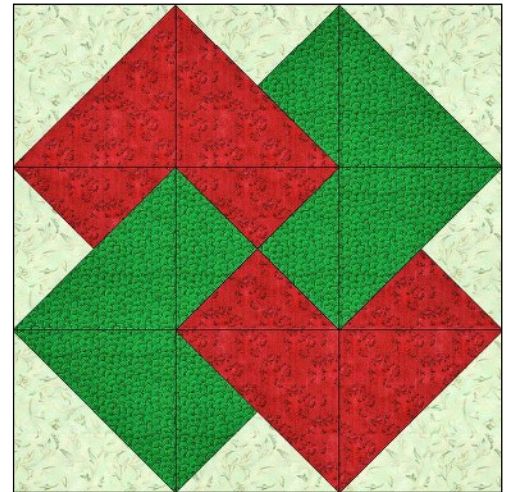

Cutting instructions

$\frac{1}{4}$ inch seam allowance is included on the templates.

Fabric 1 Cut 4 of template A
Cut 4 of template B

Fabric 2 Cut 4 of template A
Cut 4 of template B

Fabric 3 Cut 4 of template A
Cut 4 of template B

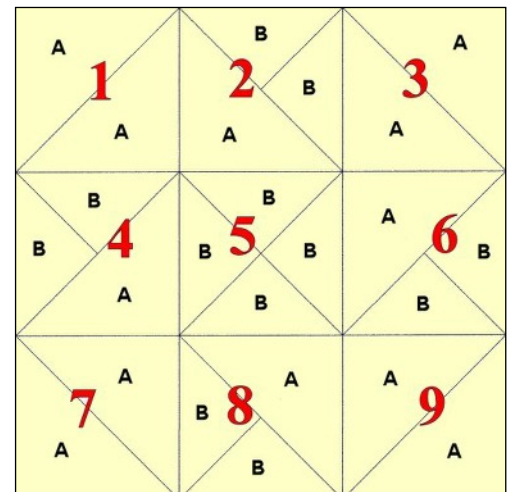

Construction

This is a nine patch block, so construct the 9 mini blocks as shown below.

1. Join 2 template A together. 1 each of fabric 2 and 3.
2. Join 2 template B together. 1 each of fabric 1 and 2.
Now join 1 template A of fabric 3 to them.
3. Join 2 template A together. 1 each of fabric 1 and 2.
4. Join 2 template B together. 1 each of fabric 2 and 3.
Now join 1 template A of fabric 1 to them.
5. Join together 4 of template B. 2 each of fabric 1 and 3.
as shown in the diagram.
6. Join together 2 of template B. 1 each of fabric 2 and 3.
Now add 1 of template A in fabric 1 to them.
7. Join together 2 template A. 1 each of fabric 1 and 2.

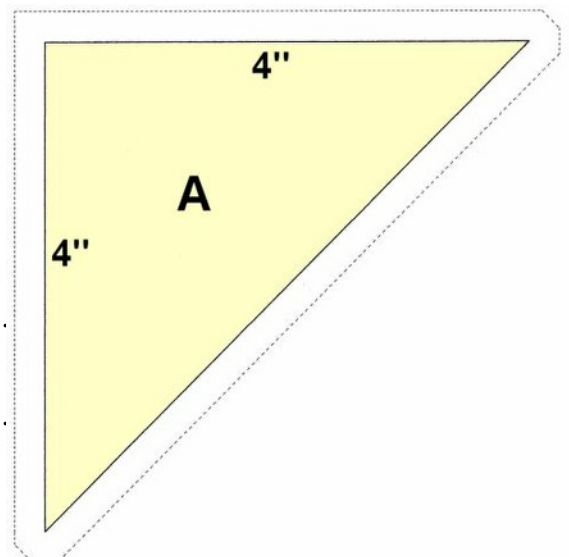

8. Join together 2 of template B. 1 each of fabric 1 and 2.
Now join 1 template A in fabric 3 to them.

9. Join together 2 of template A. 1 each of fabric 2 and 3.

You should now have 9 mini blocks.

Join together 1, 2, and 3 as shown in diagram.

Do the same for the other 6 blocks.

You should have 3 strips of 3 mini blocks.

Join as shown in diagram.

The finished block should be $12\frac{1}{2}$ inches square.

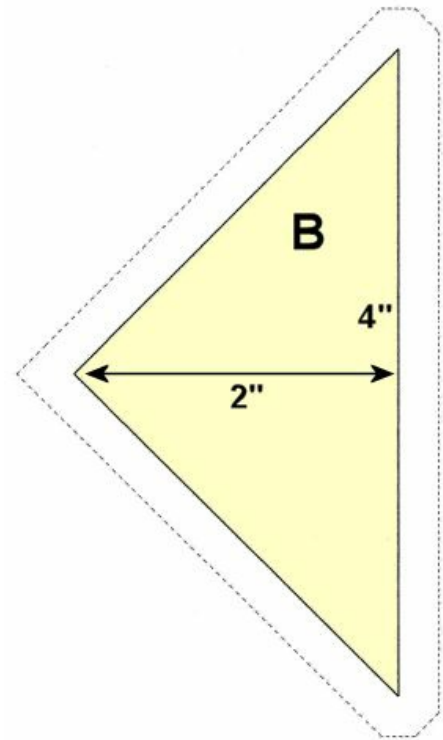

This template should be printed at 100% scale,
with paper size set to A4

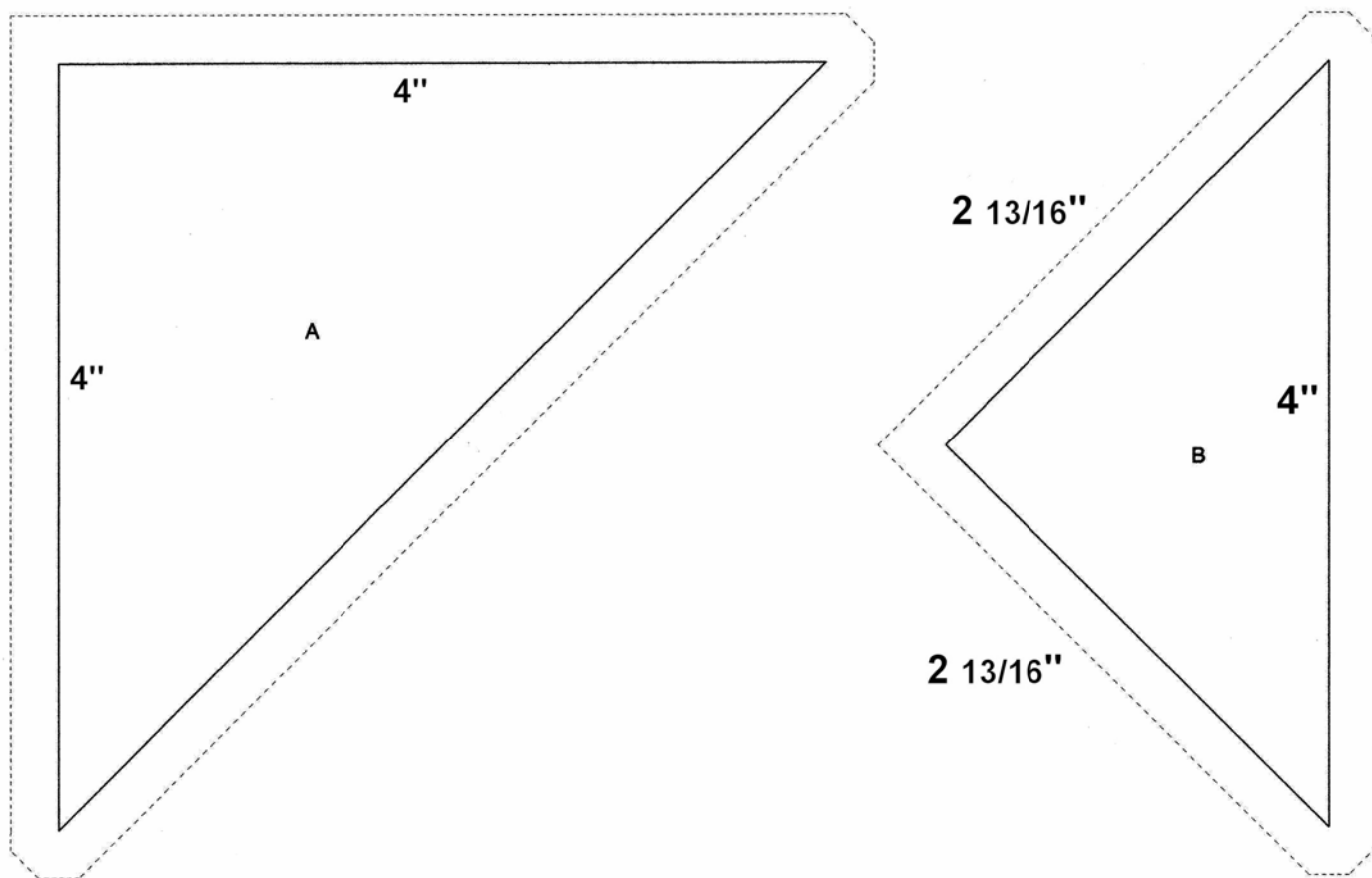

Card Trick Template